

2-Port Plus+ Regulator #170025

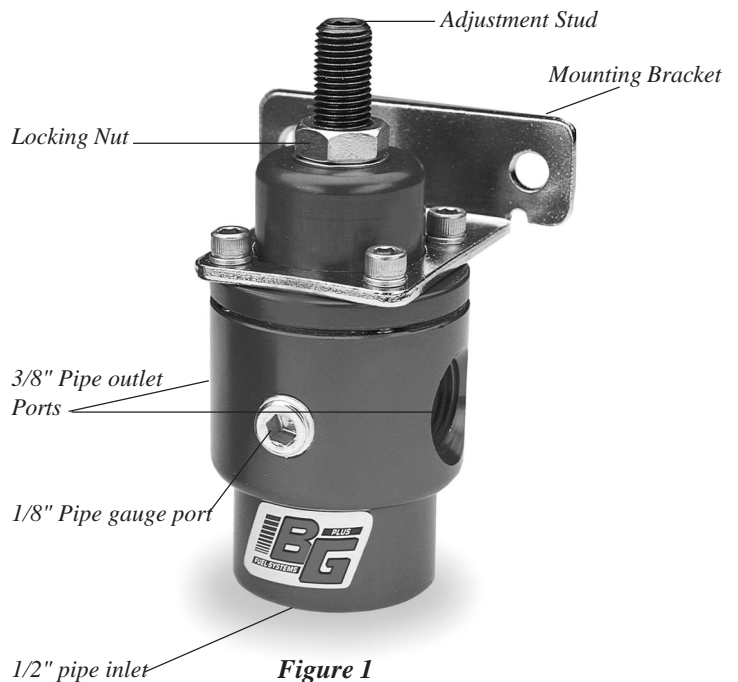

INSTALLATION AND TUNING INSTRUCTIONS

Your Two Port Regulator has been flowed and tested prior to shipping to insure proper performance on your vehicle. The pressure has been pre-set at 7 PSI. This is a good starting point. Pressure should always be set with the engine idling. Failure to do this can result in damage to the regulator's internals due to excessive over-adjustment. Turning the adjustment stud clockwise will increase pressure, counter clockwise will decrease pressure. Carburetor pressure should be set at 7 to 9 PSI depending on your application.



Standard 3/8 pipe outlet fittings can be used. However, the inlet fitting used must have a minimum inside diameter of .530 inches (See figure 2). Use of a smaller fitting will greatly impede flow and can cause internal damage. Use of BG part number 140013 accomplishes this if another fitting cannot be found.

The hole in the top of the cap is a vent and should be left open and kept clear to assure proper regulator function. Remember, after installation, check for any leaks. Your safety depends on it.

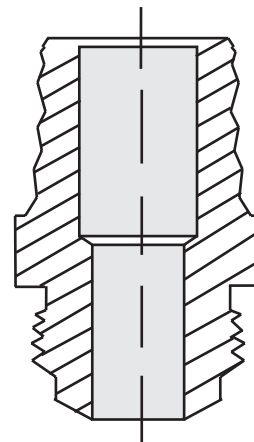

Figure 2

For further questions, please contact our technical department at (706) 864-8544.

