

*Fuel Safety
Shut-Off Valve
#171100*



INSTALLATION INSTRUCTIONS

Fuel safety shut-off valves are required on all cars equipped with belt driven fuel pumps competing in NHRA sanctioned events. The three way style valve stops fuel flow to the engine by diverting all fuel back to the fuel cell through the pump's bypass return line when the valve is actuated.

The valve needs to be installed with the three (3) #8 O-rings included and either three (3) #8 AN unions (PN 176030 or equivalent) or two (2) #8 AN unions and a bypass valve with pills (PN 170022) to assure proper sealing and function.

*Remember to check for leaks after installation.
Your safety depends on it!*

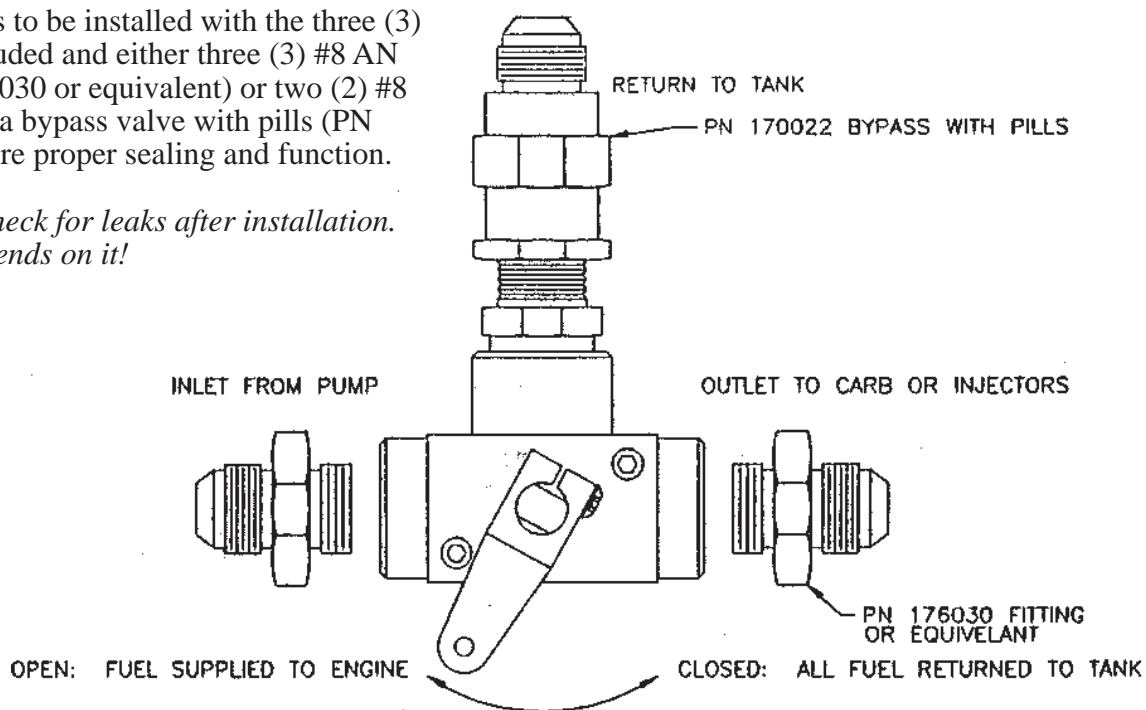

For further questions, please contact our technical department at (706) 864-8544.