

*BG Fuel Systems
Mighty Sumo Fuel Pump
Part #170041*



INSTRUCTION MANUAL

- Safety
- Contents
- Installation
- Operation
- Maintenance

VITAL INFORMATION BELOW-PLEASE READ SAFETY AND OPERATING INSTRUCTIONS BEFORE FIRST USE OF THIS PRODUCT

For answers to your questions concerning this product, please contact the **BG Fuel Systems Technical Department** at (706) 864-8544 from 8:00 AM until 6:00 PM, Monday till Friday (Eastern Standard Time) or visit the Barry Grant, Inc. website at www.barrygrant.com

SAFETY INSTRUCTIONS

Warning: When using fuel systems designed for performance and racing vehicles, basic safety precautions must always be followed to reduce the risk of fire and serious injury. The installer and operator are responsible for following the warnings and instructions in this manual. Please read the entire instruction manual before using this product. Restrict the use of this product to only those who are familiar with the installation and operating instructions.

- Fuel is combustible; therefore, be careful not to drip any fuel on a hot engine or hot components.
- Inspect all fittings and connections prior to use and make sure they are tight and leak-free. Your safety depends upon it.

CONTENTS OF THIS BOX

- 1- BG Mighty Sumo Fuel Pump with fittings installed (-10 AN inlet and -8 AN outlet)
- 1- Instruction Manual complete with wiring and plumbing diagrams

INSTALLATION and OPERATION

The Mighty Sumo by BG Fuel Systems is a continuous-duty-style electric fuel pump. It is rebuildable and features an integral ultra-fine 8-



micron filter with a dry-break valve to aid in servicing the filter element. Designed for fuel-injected applications with power outputs of up to 750 HP, the Mighty Sumo pump will produce a flow of fuel in excess of 375 lb/hr at 60 psi. It features a preset non-adjustable bypass, which is set at 75 PSI.

The Mighty Sumo pump is designed for use with unleaded and leaded gasoline. However, it is not designed for use with methanol. **Use of methanol in the Mighty Sumo fuel pump voids all warranty claims.**

Mounting

The Mighty Sumo pump should be gravity-fed and mounted as close to the fuel tank or cell as possible. Position it level with or below the outlet of the fuel tank/cell and attach it to a solid frame member using the mounting brackets provided. Do not allow the motor housing to touch any metal components of the vehicle, as this can affect the performance of the motor and the pump. **THE PUMP SHOULD NEVER BE MOUNTED IN THE DRIVER'S COMPARTMENT OR NEAR ANY MOVING PARTS OR CLOSE TO THE EXHAUST OR OTHER HEAT SOURCE.**

Inlet Port

(located at the end with the internal filter)
Use a -10 fuel line to connect the Mighty pump to the tank or cell. This may necessitate removing and modifying the existing tank or cell and inserting a -10 fuel cell bulkhead fitting (PN 140036)

and a -10 hose-end 90° fitting (PN 4034) in its lowest and rearmost region.

For the more professional installation, use a fuel tank sump kit (Moroso PN 4041). These sump kits, which are equipped with two 1/2" NPT outlets, are welded into the lowest and rearmost region of the tank and provide a consistent reservoir of fuel even under rapid acceleration. To connect the -10 braided-steel fuel line to the sump, use an adaptor 1/2 NPT to -10 (PN 2009). Plug the remaining sump bung with a 1/2 NPT pipe plug (PN 3749).

To re-position the pump from the horizontal plane to the vertical, remove the blanking plug from the side inlet port (filtered end) and swap it with the -10 AN fitting at the end inlet port (filtered end). BG Fuel Systems plumbing kit PN 152287 contains all necessary fittings to extend from the fuel cell to the pump with -10AN line.

Outlet Port

(located at the end with the electrical connections)

The outlet end of the pump, which extends to the fuel pressure regulator or bypass, should be fitted with a -8AN fuel line or equivalent. To re-position the pump from horizontal to vertical, remove the blanking plug at the outlet end and swap it with the -8AN outlet fitting. BG Fuel Systems plumbing kit PN 150288 contains all necessary parts to extend from the pump outlet to a BG Fuel Systems fuel pressure regulator (PN 170025) or bypass (PN 171021) or fuel log (PN 170031).

Vent

For the fuel pump to operate properly, it requires a filtered vent at the top of the fuel tank or cell. Use a vent hose with a minimum bore of -8AN or 1/2-inch. **Failure to use a vent will damage the pump.**

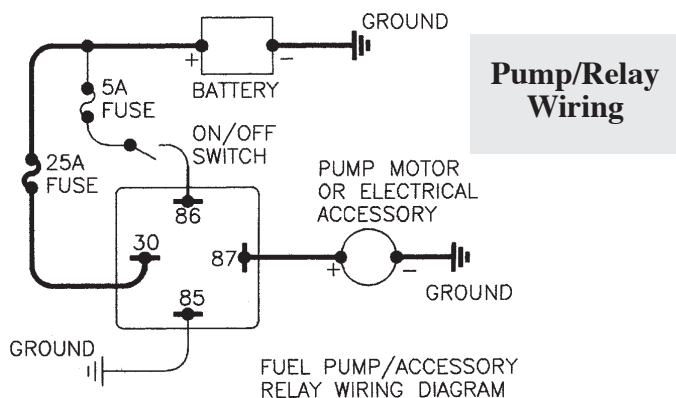

Do not mount the fuel vent where it can become blocked with debris or is vulnerable to the ingress of water. Ensure that all fuel system components are leak-free before using your system. Your safety depends on it.

Wiring

BEFORE MAKING ELECTRICAL CONNECTIONS, DISCONNECT THE BATTERY. The Mighty Sumo fuel pump should be connected to a fully charged 12- or 16-volt battery. Like other electrical accessories, a fuel pump will perform better if given adequate voltage. Therefore, wire the pump through a relay (PN 171035); thus, reduce voltage loss. Run a 12-gauge wire from the battery to the relay and from the relay to the pump using a 25-amp fuse in the circuit to protect the pump. Use 18-gauge wire to activate the relay.

On street-driven vehicles, install a pressure-safety switch (PN 16006) to prevent the pump operating when the engine is stopped (See Diagram).

The pump is equipped with bolt-style electrical terminals to connect it to the wiring with ring connectors. The pump must be grounded to a clean chassis connection using a minimum of 12-gauge wire. Refer to both the wiring and plumbing diagrams provided. **ALL WIRING CIRCUITS MUST BE FUSED.** Finally, reconnect the battery.

Tuning and Adjustment

Fill the tank and ensure that fuel is present at the inlet port of the fuel pump before attempting to run it. The presence of fuel is confirmed by cracking open the inlet fitting. Retighten the fitting before proceeding. If the pump does not draw fuel within 20 seconds, **STOP** and prime the pump. Operating the pump while dry will damage it.

Because the Mighty Sumo pump provides more fuel than most pumps on the market, it may be necessary to re-tune the air/fuel ratios to maintain optimum performance.

MAINTENANCE

The following tips should be followed to ensure maximum performance and longevity from your BG Fuel Systems Mighty Sumo pump.

1. Confirm that the system is operating properly by checking the fuel pressure at the regulator while the motor is running. Note: BG Fuel Systems recommends a dampened non-liquid filled

gauge (PN171024). Liquid filled gauges are affected by ambient temperatures and can display false readings.

2. If the vehicle is stored for long periods of time, operate the pump for several minutes each week. Alternatively, remove the pump from the vehicle, spray light lubricating oil into it, and store it in a sealed bag until it is to be used.

3. Regularly check your braided steel lines for internal deterioration. Deterioration occurs with aging and can be identified by soft spots while squeezing the fuel lines by hand.

4. Depending upon usage, the fuel filter (P/N 171049) should be inspected at least once a year, if not more often. To inspect the fuel filter, remove the four screws that attach the end of the inlet housing to the body. This portion of the pump features a dry-break valve to prevent the fuel draining from the fuel tank or cell.

5. Should you have a problem or questions regarding the setting up or tuning of this fuel pump, please contact the BG Fuel Systems technical department directly at (706) 864-8544 or visit the Barry Grant Inc website at www.barrygrant.com

Note: The Mighty Sumo is covered by a lifetime labor warranty. Inspections, flow testing, and repairs are free-the only payment required is for parts used (if any).

Remember, when sending in parts for service, please include a description of the problem, a return address, and a day time phone number.

BG Mighty Sumo Fuel System

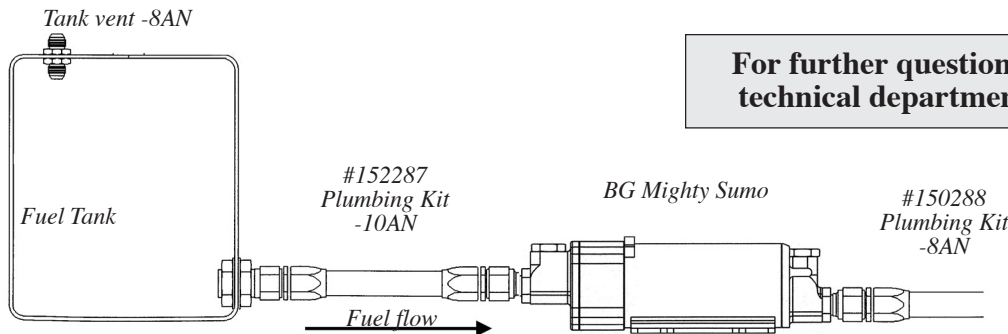

For further questions, please contact our technical department at (706) 864-8544.

WARRANTY

All Barry Grant, Inc. Products are covered by a limited warranty for 90 days from the date of purchase. Proof of purchase must be included with all returns and must include date of purchase. In the event of a defect in workmanship or material of the product, Barry Grant, Inc. will repair or replace the product, or any defective parts or parts thereof, at the election of Barry Grant, Inc. without charge to the consumer for such repair or replacement. The Limited Warranty shall not apply to labor charges, material or other incidentals in connection with removal and/or replacement of such defective product on the Consumer's vehicle.

This Limited Warranty is specifically limited to the original purchaser of the product and is enforceable only by such original purchaser.

The maximum liability of Barry Grant, Inc. in connection with this warranty shall not under any circumstances exceed the contract price of the product claimed to be defective.

This Limited Warranty shall *not apply* and shall become fully null and void, in the event of damage to the product resulting from any of the following: Unauthorized repairs; Breakage due to dropping or misapplication; Repair, alteration or modification of the product by anyone other than the manufacturer, or authorized representative thereof; Damage resulting from accidents; Abuse or misuse of the product in any manner whatsoever; Damage resulting from incorrect or improper installation. This Warranty is the only warranty applicable and is expressly in lieu of all other warranties, expressed or implied, including any implied warranty of merchantability or fitness for purpose.

**Barry Grant, Inc.
1450 McDonald Road, Dahlonega, Georgia 30533**

Sumo Essentials in Brief:

1. Use a -6 return line from the Bypass to the fuel tank/cell. The internal fuel-return pipe (in the fuel tank/cell) must also be of -6 dimensions (3/8" bore) and terminate at the bottom of the fuel cell in the front region of the tank. Under no circumstances should returning fuel be discharged above the fuel level. Discharging fuel into the cell above the fuel level will aerate the fuel and destroy the Sumo pump.
2. The internal fuel outlet pipe (in the fuel tank/cell) must be -10 (5/8" bore) and be located in the rear region of the fuel tank, preferably in a recessed sump. The inlet and outlet openings are positioned as far apart as possible to prevent aerated hot fuel from entering the inlet pipe.
3. To vent the fuel tank/cell to atmosphere, use a minimum size of -8 (1/2" bore). Use a vent filter and terminate the vent line such that it can neither become blocked with debris nor open to the entry of water.
4. Install the Sumo at or below the level of the fuel tank/cell outlet and in a position that will not subject it to heat or vibration; do not mount the Sumo between the rear axle and the fuel tank or close to the exhaust system. Neither should fuel lines reside close to the exhaust.
5. If the vehicle is to be used for cruising rather than racing, install a heat sink (P/N 178000) between the fuel pump and fuel rail.
6. Use a -10 line from the fuel cell to the fuel pump.
7. Use a -8 line from the fuel pump to the fuel rail.